

Quadrant Photodiode Amplification Module SiQu9UV-M



Phresh Photonics' SiQu9UV-M is a complete module that combines a Silicon Quadrant Photodiode with amplifiers and position sensing circuitry in a practical 2" X 1.25" rugged UL approved housing. With excellent response in the Vis-NIR this module can be used with most any light source. The **SiQu9UV-M** provides output voltages of both the sum of the quadrants as well as the differences of Top minus Bottom and Left minus Right. This module can be used to very accurately determine the location and position of a light beam. Alternative versions with larger quads are also available. Typical applications include laser beam alignment (including in a feedback loop) and target acquisition.

Specifications:

Total Sensing Area	9mm ² (3 X 3 mm)
Separation between Quadrants	100µm
Spectral Response	190-1000nm
Supply Voltage	15V typ (5-18V)
Output Voltage	+V _{CC} -3 ; -V _{CC} +3
Output Current Limit	25 mA
Maximum Slew Rate	10V/µS
Frequency Response (-3db)	250kHz
Noise (theoretical)	15nV/ √Hz
Operating Temperature	0-70°C

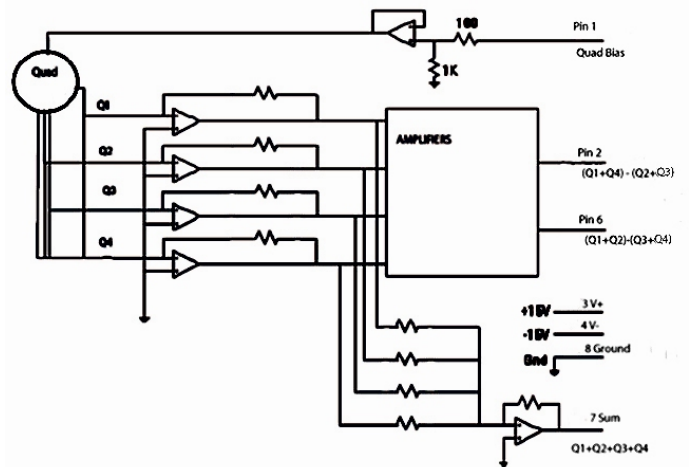

Outputs:

The **SiQu9UV-M** requires an applied voltage of 5-18V. The outputs are the current generated by the photodiode elements after amplification through a current to voltage amplifier of 1000 (10⁴). A 9 pin connector allows for easy connection.

Pin 1	= PD Bias
Pin 2	= (Q1+Q4) - (Q2+Q3)
Pin 3	= +15V
Pin 4	= -15V
Pin 6	= (Q1+Q2) - (Q3+Q4)
Pin 7	= Q1+Q2+Q3+Q4
Pin 8	= Ground

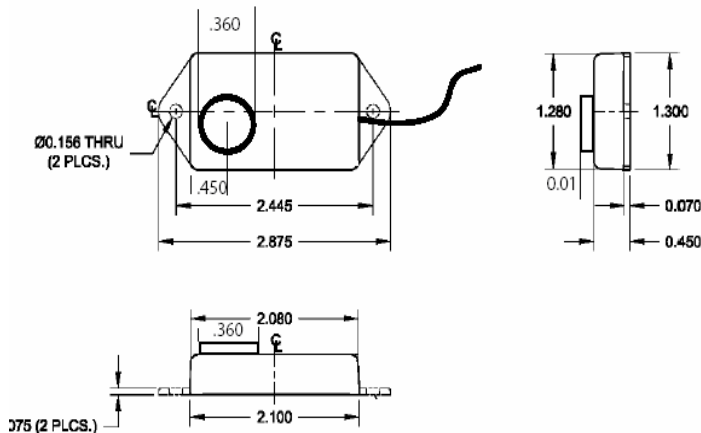

Phresh Photonics
 5737 Kanan Road: Suite #217
 Agoura, Ca 91301
 tel: 818-292-2479 fax 818-707-3616
www.phreshphotonics.com info@phreshphotonics.com